

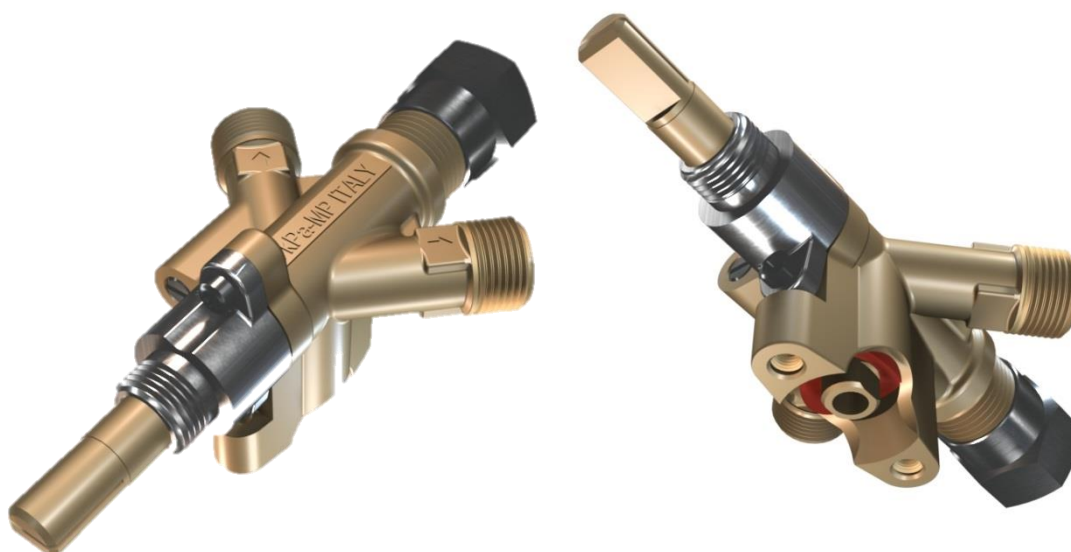

## INSTRUCTION FOR INSTALLATION, USE AND MAINTENANCE

# Art. 112



**Read the instruction before use.**  
This valve has to be installed in accordance with rules in force.



## Index

<b>1. Chapter 1</b>	<b>03</b>
1.1 Product Description	<b>03</b>
1.2 Technical Properties	<b>04</b>
1.3 Overall Dimensions	<b>05</b>
<b>2. Chapter 2 - Installation</b>	<b>06</b>
2.1 General Information	<b>06</b>
2.2 Installation and Assembling	<b>07</b>
2.3 Thermocouple Fixing	<b>08</b>
2.4 Gas Outlet Connection	<b>09</b>
2.5 Adjusting Low Flow Rate	<b>10</b>
<b>3. Chapter 3 - Maintenance</b>	<b>11</b>
3.1 General Notes	<b>11</b>

## Chapter 1

### 1.1 - Product description

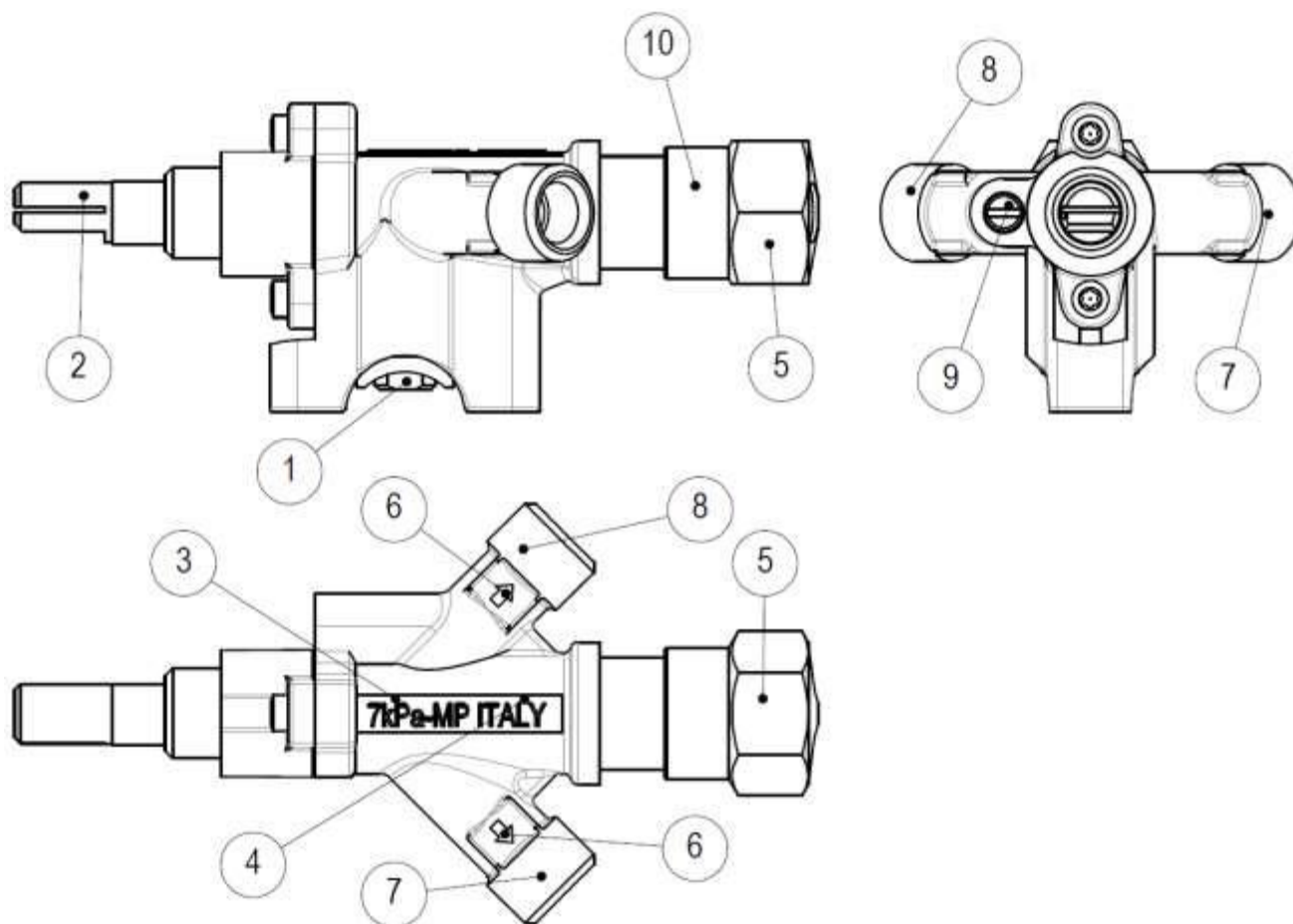

1. Gas inlet (Tube  $\varnothing$  16 –  $\varnothing$  10 –  $\varnothing$  8)
2. Spindle for knob
3. Max. working pressure (7kPa for CE and 1/2 psi for CSA)
4. Manufacturer
5. Fitting thermocouple
6. Gas flow direction
7. First gas outlet (oven)
8. Second gas outlet (grill)
9. Low adjusting screw first outlet
10. Production date (year/week or production batch), valve code and max. temperature

## 1.2 - Technical properties

<b>CE Approval:</b>	in accordance to <b>GAR EU/2016/426</b> – Certificate N°: <b>CE-0085AQ0789</b>
Working temperature:	0 °C -150°C
Max working pressure:	7kPa (65 mbar)
Working angular rotation first outlet:	+160°
Working angular rotation second outlet:	- 90°
Position of maximum:	90°
Gas inlet connection:	clamp-on for $\varnothing$ 16, $\varnothing$ 10 and $\varnothing$ 8 manifold
Gas outlet connection:	$\frac{1}{4}$ Gas
Knob shaft connection:	max. $\varnothing$ 8
Fitted with:	adjustable low rate screw
Fitted with:	safety device for flame control
Applications:	cooking
Group:	2
Kind of gas:	I, II, III
Tap endurance test:	40.000 (CE) - 10.000 (CSA)
Safety device endurance test :	10.000 (CE) - 6.000 (CSA)

**Flow rates manifold:**  $\geq \varnothing 16$

**Flow rate index 1° outlet:** ( $\Delta p=2,5$  mbar):  $\geq 95\%$  of **0,289 m<sup>3</sup>/h**

**Flow rate index 2° outle:** ( $\Delta p=2,5$  mbar):  $\geq 95\%$  of **0,277 m<sup>3</sup>/h**

### 1.3 - Overall dimensions

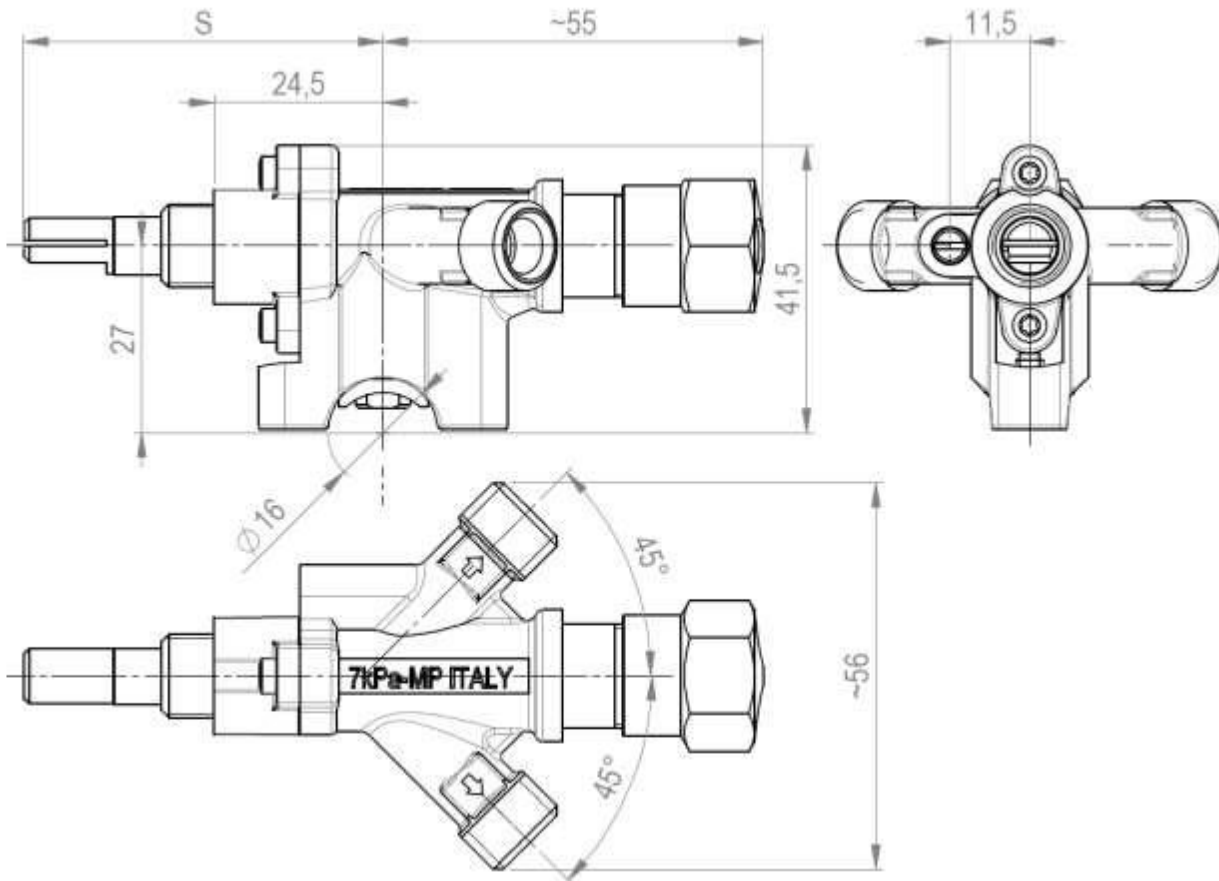

## Chapter 2 - Installation

### 2.1 - General Information



Failure to comply with the following requirements may prevent the correct operation and safety of the product.

1. All installation, connection and adjustment operations must be performed only by **qualified personnel** and according to the specific properties of the device;
2. During installation it is important to verify that the **gas flow is in accordance with the arrow** on the valve body;
3. To avoid damage that may compromise correct functioning of the valve, **do not exceed the tightening torques** listed in next chapters;
4. To avoid damage that may compromise correct functioning of the valve, handling of valve shall be taken care of: **avoid falls and bumps**;
5. To avoid damage that may compromise correct functioning of the valve, use the **appropriate tools for installation** operations;
6. To ensure a perfect seal, manifold **shall not present burrs** in correspondence of valve installation hole;

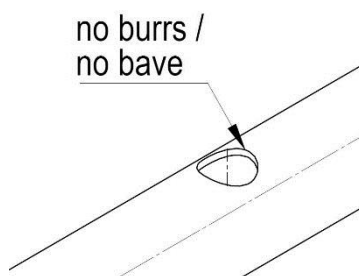

7. In order to avoid any foreign body to enter into the valve, which could compromise the right functioning of the valve, **manifold shall be clean**. A suitable **filter** should be mounted **on the manifold supply inlet**.



After installing or replacing the valve / valves, the installer must always check for gas leakage.

## 2.2 - Installation and assembling

Fix the gas valve on the manifold by the means of apposite screws and bracket, as shown on **fig. 1** and **fig. 2**

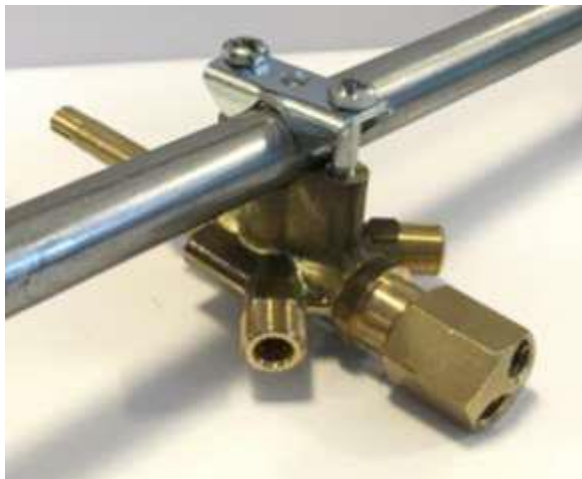

**fig. 1 – Ø 16 manifold**

1. Bracket Ø 16 tubing (Cod.18019)
2. M5 Screw s (Cod.18031)

**Ideal torque: 1 Nm**

**Max. torque: 2 Nm**



**fig. 2 – Ø 8 & Ø 10 manifold**

3. Bracket Ø 8 Tubing (Cod.28020)
4. M3,5 Screws (Cod. 18091)

**Ideal torque: 0,8 Nm**

**Max. torque: 1 Nm**

## 2.3 - Thermocouple fixing

Fix the two thermocouples to the thermostat using the two threaded connections shown on fig. 3.  
Screw-in the nut of thermocouple with a torque of 4 Nm max.



fig. 3

Available magnet-on and magnet-off currents:

- 200 / 40 mA



## 2.4 - Gas outlet connection

Fix the gas outlet tube to the valve, according to the type of outlet on the body, as show in **fig. 4**; in order to avoid any damages which could prevent the right functioning of the valve, please follow strictly the tightening torques shown in **TABLE 1**.

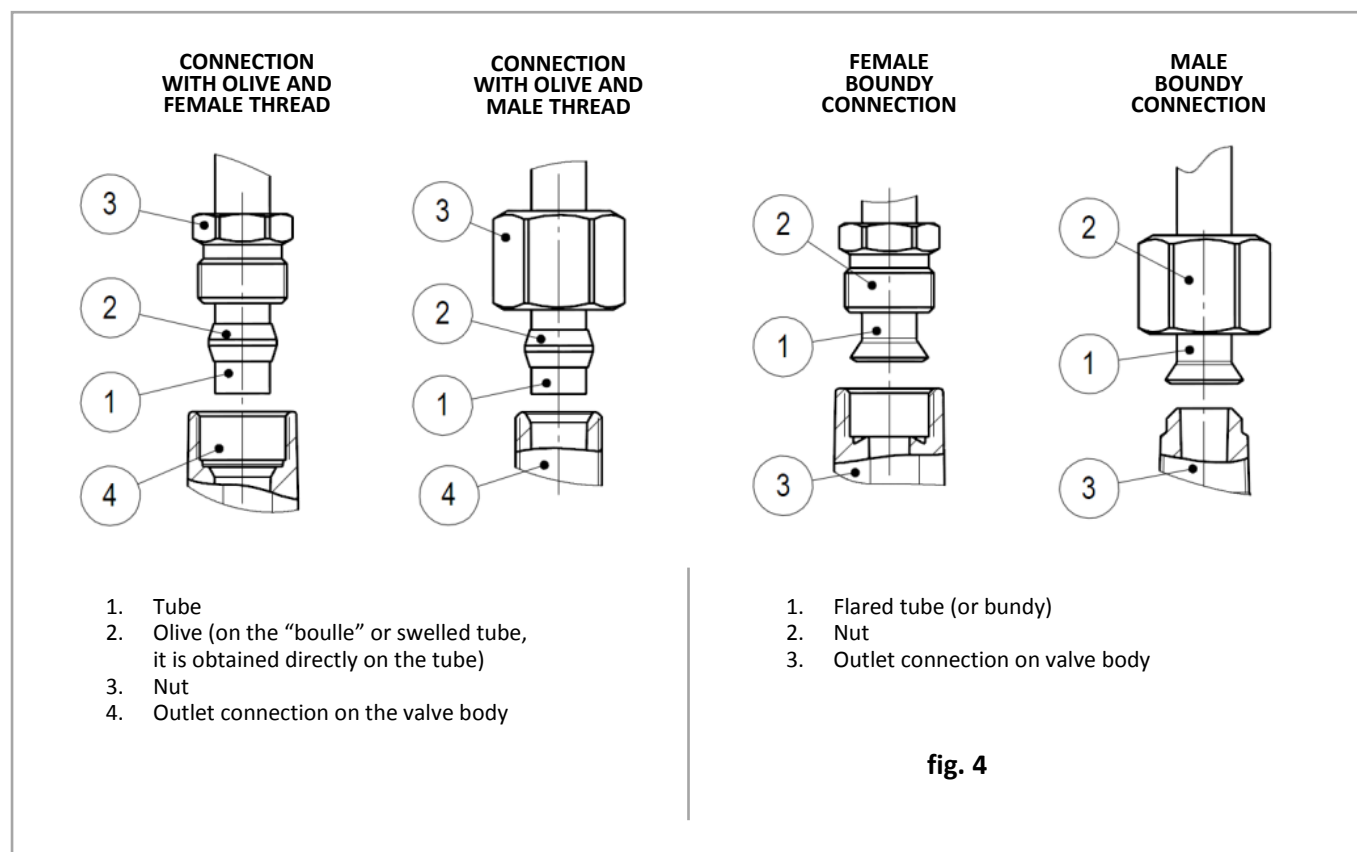

**TABLE 1: maximum tightening torques (C max)**

Component	Cmax	
	Nm	lbf.in
Nut + olive + aluminium tube	15	133
Nut + olive + copper tube	15	133
Nut + olive + steel tube	10	89
Nut + aluminium flared tube (boundy)	15	133
Nut + aluminium swelled tube ("boulle")	15	133

## 2.5 - Adjusting low flow rate

The valve is fitted with an adjusting by-pass drilled and adjustable which, screwed-in till the end, fixes the reduced flow rate at an established value.

The adjustment of the reduced flowrate, in case of change of the kind of gas, is obtained by screwing or unscrewing the by-pass by the means of a screwdriver; while unscrewing the by-pass, the flowrate is increasing, on the contrary, while screwing it, it is decreasing.

The by-pass is located into the valve so to adjust it a screwdriver with spindle of  $\varnothing 2,5$  or  $\varnothing 3.3$  have to be used; to reach the screw shaft must be inserted in the hole of spindle of knob, as shown in **fig. 5** below.

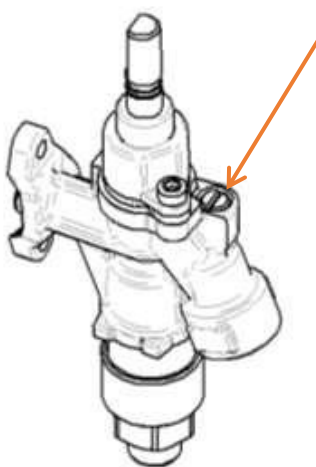

fig.5



**Attention:** removing the adjustment screw can cause large gas leaks. The replacement of the screw, where possible, must be performed by a **qualified personnel**.

## Chapter 3 - Maintenance

### 3.1 - General notes

All installation, connection and adjustment operations must be performed only by qualified personnel and according to the specific properties of the device. During installation it is important to verify that the gas flow is in accordance with the arrow on the valve body.

The valves are designed in order to be able to operate inside the cooking appliances, protected by any possible liquids or dirty infiltrations and by the atmospheric agents. The non-compliance of such a prescription may prevent the right functioning and the safety of the product.

It is absolutely forbidden to tamper with the sealed parts, unscrew the assembling screws and remove any part or marking on the valve. It's good to avoid that the valve suffers any kind of shocks (bumps, falls etc.)

In order to avoid any foreign body to enter into the valve, which could compromise the right functioning of the valve, it is necessary to assemble a proper filter; the inlet filter must be provided upstream of the manifold as required by the standard.



**No kind of maintenance on the valve is allowed.** It is absolutely forbidden to Tamper with the sealed parts, unscrew the assembling screws and remove any part or marking on the valve. The parts of the device mounted or adjusted during manufacturing and not intended for manipulation by the user or installer must be adequately protected.

## Info and contacts

**MP GAS CONTROLS S.P.A.**  
VIA NEZIOLE 2  
25055 - PISOONE (BS) - ITALY  
+39 0364 89020  
info@mpgascontrols.com